

Installation, Operating, Maintenance
and After Sales Manual.

KICKSPACE® 500, 600, 600-12V & 800



heatingthroughinnovation.

heatingthroughinnovation.

After Sales Service:

MYSON Service, Somerden Road, Hull, East Yorkshire HU9 5PE
T: 01482 713927, F: 01482 789056, service.convectors@myson.co.uk

Spare parts and technical help on all Convector products are available from MYSON Service.

Product Serial Number:

--	--	--	--	--	--	--	--

Please leave this manual with the end user.

Part Number: 1370054
Issue 3

01.03.2008 ISSUE 3



Contents

1.0	General Information	03
2.0	Heating System Design	03
3.0	Selection and Sizing for Heating	03
4.0	Location	03
5.0	Preparation	03
6.0	Electrical Connection	04
7.0	Water Connection	05
8.0	Fitting the KICKSPACE®	06
9.0	Technical Data	08
10.0	Operating Instructions	09
11.0	Troubleshooting	10
12.0	Maintenance	11

1.0 General Information

- This MYSON KICKSPACE® fan convector is designed for installation in the cavity beneath kitchen cupboards on the vacant floor space, or other similar locations.
- No rear access shall be available to the unit after installation.
- The KICKSPACE® should only be used on closed circulation, two pipe, pump assisted central heating systems.
- Before proceeding with the installation, the heating system design must be considered and the unit correctly sized to meet the heat loss requirements of the room.
- Flexible hoses with integral isolating valves are supplied to allow easy installation and future access for maintenance.
- KICKSPACE® is supplied with integral controls including fan speed selector and summer/winter switch.
- In heating mode a low limit thermostat prevents the fan from operating if the heating system water temperature is below 43°C.
- In summer mode the fan can be operated to circulate a flow of air without any heat supply.
- The KICKSPACE® 600-12V is supplied with a separate 12V transformer that enables the unit to be fitted in a bathroom. Both the unit and the transformer must be positioned in accordance with local and national regulations.

The KICKSPACE® 500, 600 & 800 MUST NOT be installed in a bathroom or other similar high humidity area.

2.0 Heating System Design

This fan convector must be fitted on a two pipe, pumped circulation heating system.

For optimum fan convector heating performance the system must be capable of providing sufficient hot water through the heat exchanger. This means that:

1. The minimum pipe size from boiler to fan convector must be at least 15mm. Microbore pipe **MUST NOT** be used.
2. Where the unit is fitted on to a system with other emitters a separate circuit for the fan convector should be considered to provide adequate water flow.
3. The system water must be above 43°C for fan to switch on, and for satisfactory operation the mean water temperature should not be below 60°C.
4. **This unit is NOT suitable for one-pipe systems.**
5. Optimum performance will require effective balancing of the whole system.
6. It is not recommended that this unit is used to replace a radiator in an existing system unless an adequate flow of water can be guaranteed.

3.0 Selection and Sizing for Heating

- Heat output performance is given in the Technical Data section of this manual.
- Since KICKSPACE® units are supplied with fan speed control it is important to size the unit to match the calculated heat loss requirements of the room with the unit operating at the low fan speed.
- The higher fan speed can then be used for more rapid heating from cold in extreme conditions.

4.0 Location

- This KICKSPACE® unit is designed for installation in the cavity beneath cupboards in kitchens or other similar locations on the vacant floor space.
- When installed in a kitchen consideration should be given to storage of perishable goods in the cupboard above.
- A minimum of 25mm clear headroom is required above the top of the KICKSPACE® when fitted.
- The unit should be mounted on a clean and level floor area under the cupboard base.

5.0 Preparation

Before proceeding with the installation, unpack the carton contents and check against the checklist below:

1. KICKSPACE® unit.
2. Flexible hoses including isolating valves (1 pair).
3. Instruction manual.
4. Warranty card.
5. Grille.
6. Screw fixing kit (with grille).
7. Transformer (12V model only).
8. Connector (12V model only).

1.0

2.0

3.0

4.0

5.0

5.0 Preparation (continued...)

- A clean and level floor area is required under the cupboard base.
- Floor mounting - The KICKSPACE® is normally fitted directly onto the floor and the base of the unit is fitted with four mounting feet.
- Plinth mounting -
 - As an alternative to floor mounting the unit may be fitted into the plinth.
 - A suitable support must be securely fitted to the floor.
 - The top of the support must be level with the lower edge of the cut-out when fitted.
- Decide the position of the KICKSPACE®, mark out and cut the plinth to the dimensions of Fig. 1a (floor mounting) or 1b (plinth mounting).

Model	Dimensions (mm)	
	A	B
500	466	99
600 & 600-12V	520	99
800	575	99

A = Width of cutout
B = Height of cutout

Note: unit dimensions given in Technical Data section 9.

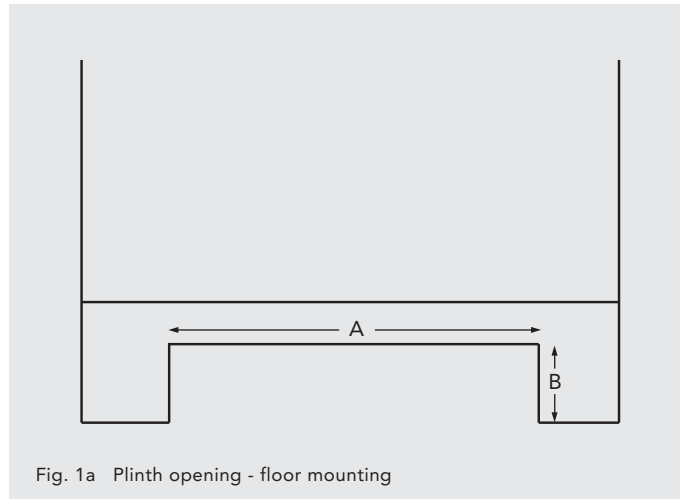

Fig. 1a Plinth opening - floor mounting

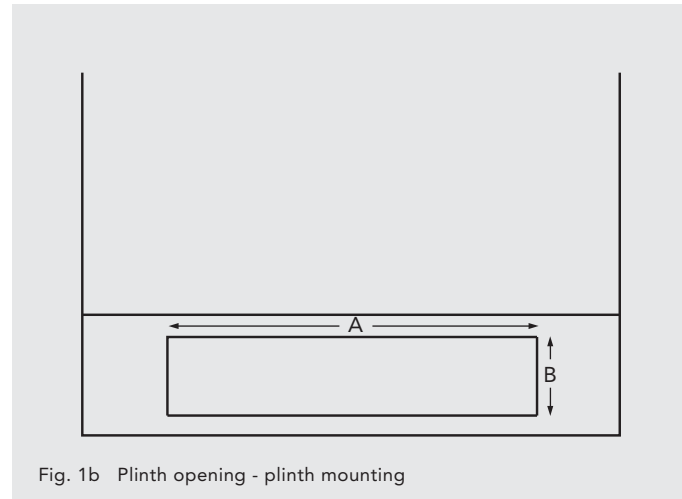

Fig. 1b Plinth opening - plinth mounting

6.0 Electrical Connection

WARNING: This appliance must be earthed.

- The electrical installation must comply with local or national wiring regulations.
- This unit is supplied fitted with a 2 metre 0.75mm² cord.
- For KICKSPACE® 500, 600 and 800, a fused (3A) electrical spur with a switch having 3mm separation on all poles must be provided in an easily accessible position adjacent to the unit.
- For the KICKSPACE® 600-12V, a fused electrical spur having 3mm separation on all poles must be provided in an easily accessible position adjacent to the transformer. Both the fused spur and the transformer must not be positioned in a bathroom or other similar high humidity installation.
- Room Thermostat - If a remote room thermostat is required, wire it into the fused spur at this stage.
- Remote Control Switch - A remote control switch is available as an accessory, and if required should be wired at this stage.
- If the supply cord is damaged, it must be replaced by the manufacturer, its service agent or similar qualified persons in order to avoid hazard.
- For the KICKSPACE® 600-12V, a connector block is supplied to connect the low voltage supply from the transformer to the supply cord fitted to the unit.

Do not energize the electrical supply until the remaining stages of the installation have been completed.

7.0 Water Connection

Pipework must be positioned correctly to ensure flexible hoses are not kinked when installed. See Fig. 3. Only use the hose sets supplied with this unit. Do not use old or alternative hose sets.

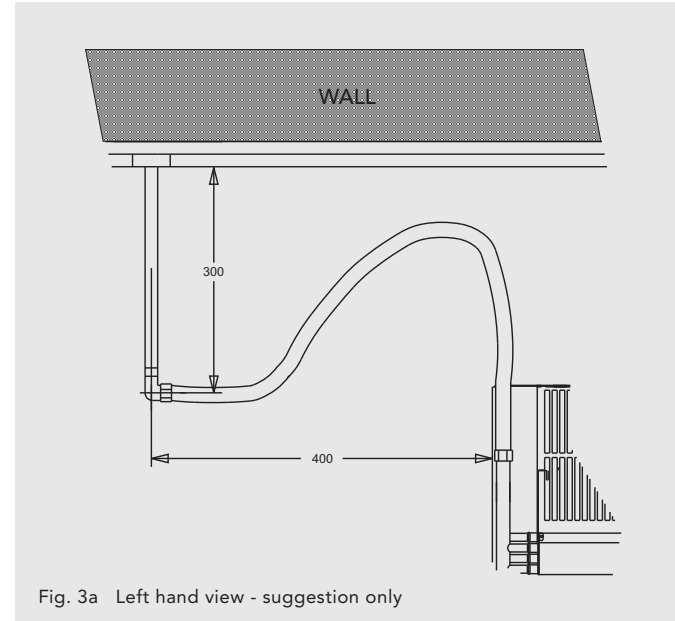

Fig. 3a Left hand view - suggestion only

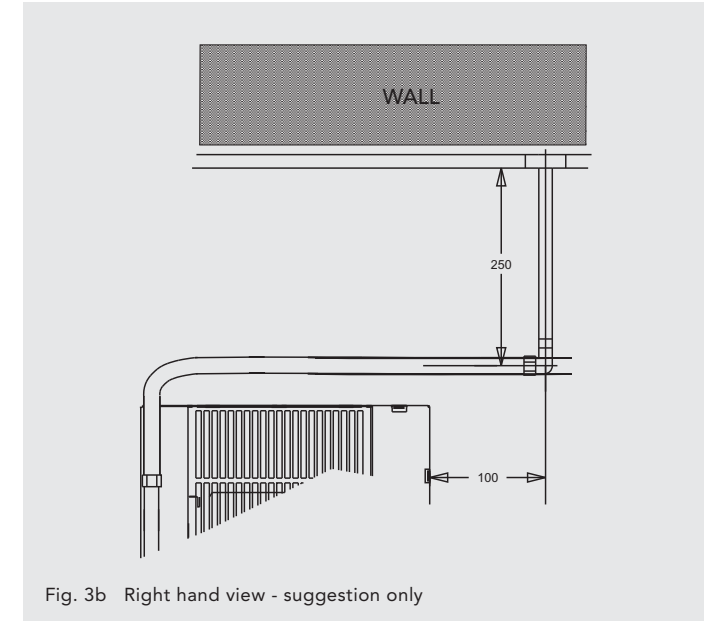

Fig. 3b Right hand view - suggestion only

- Connect valve ends of the flexible pipes to the KICKSPACE®.
- Note:** The direction of the arrows on the valves are not significant in this application.

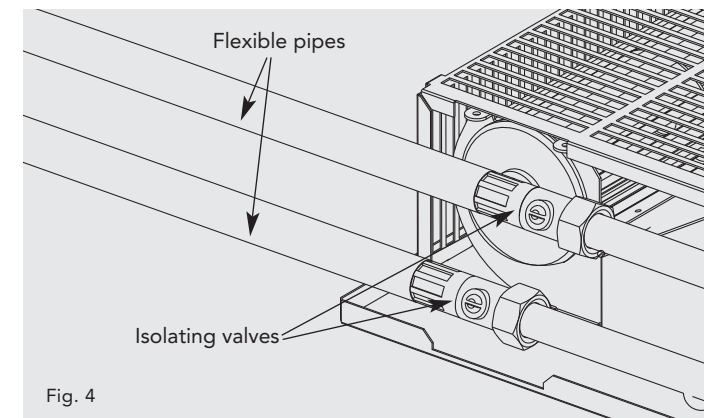

Fig. 4

- Open valves fully, check pipe connections for leaks and vent the heat exchanger. A vent screw is provided to vent the heat exchanger.

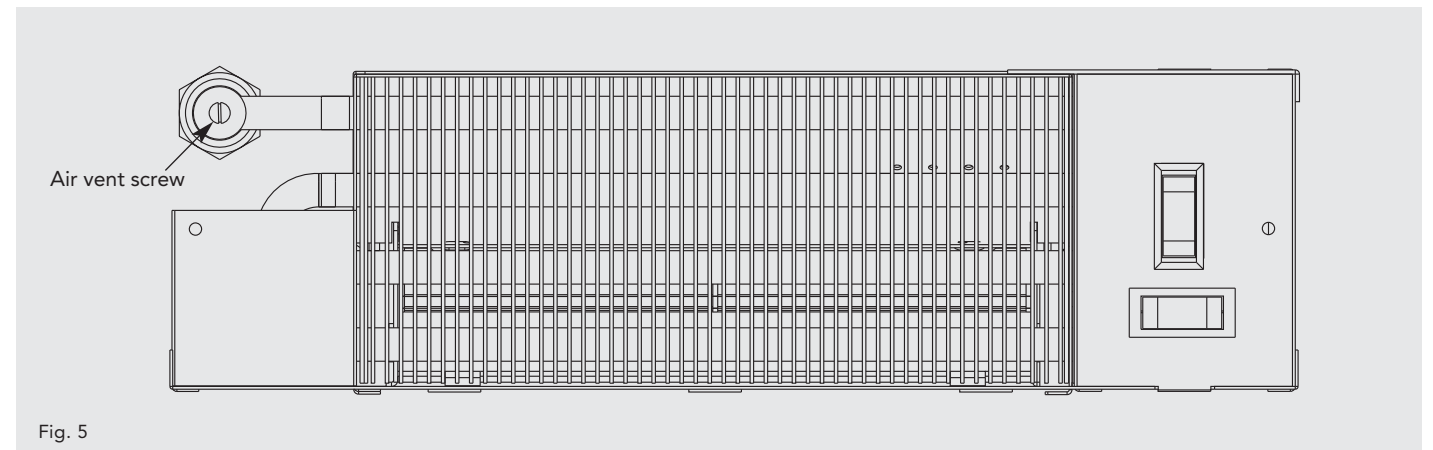
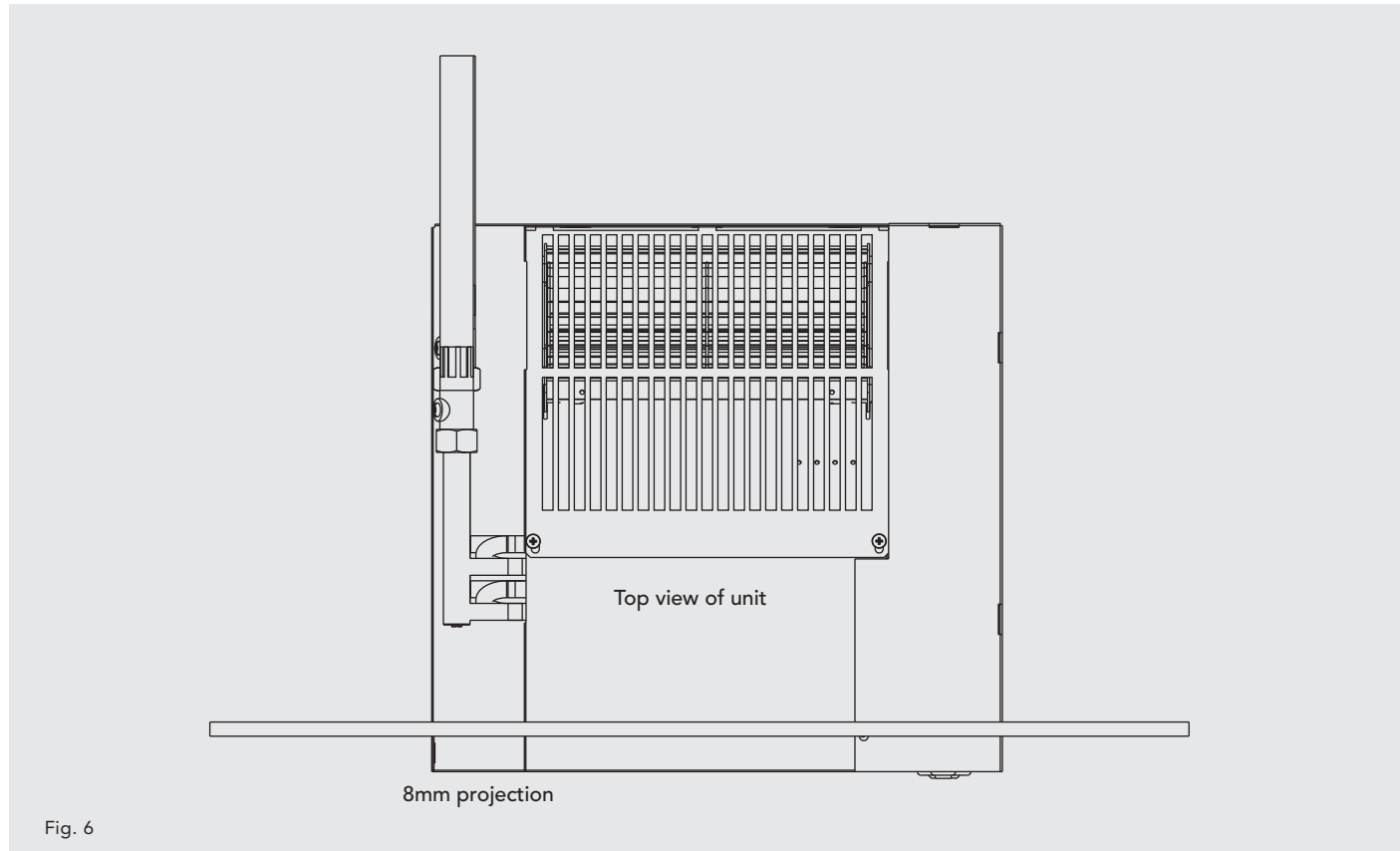

Fig. 5

8.0 Fitting the KICKSPACE®

- Position the KICKSPACE® under the cupboard in the required location, with the front edge just behind the line of the plinth.
- Ensure that the flexible hoses are not kinked and that the electrical cord is not in contact with hot surfaces.
- Replace the plinth and bring the KICKSPACE® forward into the opening so the front edge projects 8mm through the plinth.



- Align the grille and secure it to the unit with two screws supplied (use the shorter screws).
- Secure the unit/grille to the plinth with two screws supplied (use the longer screws).

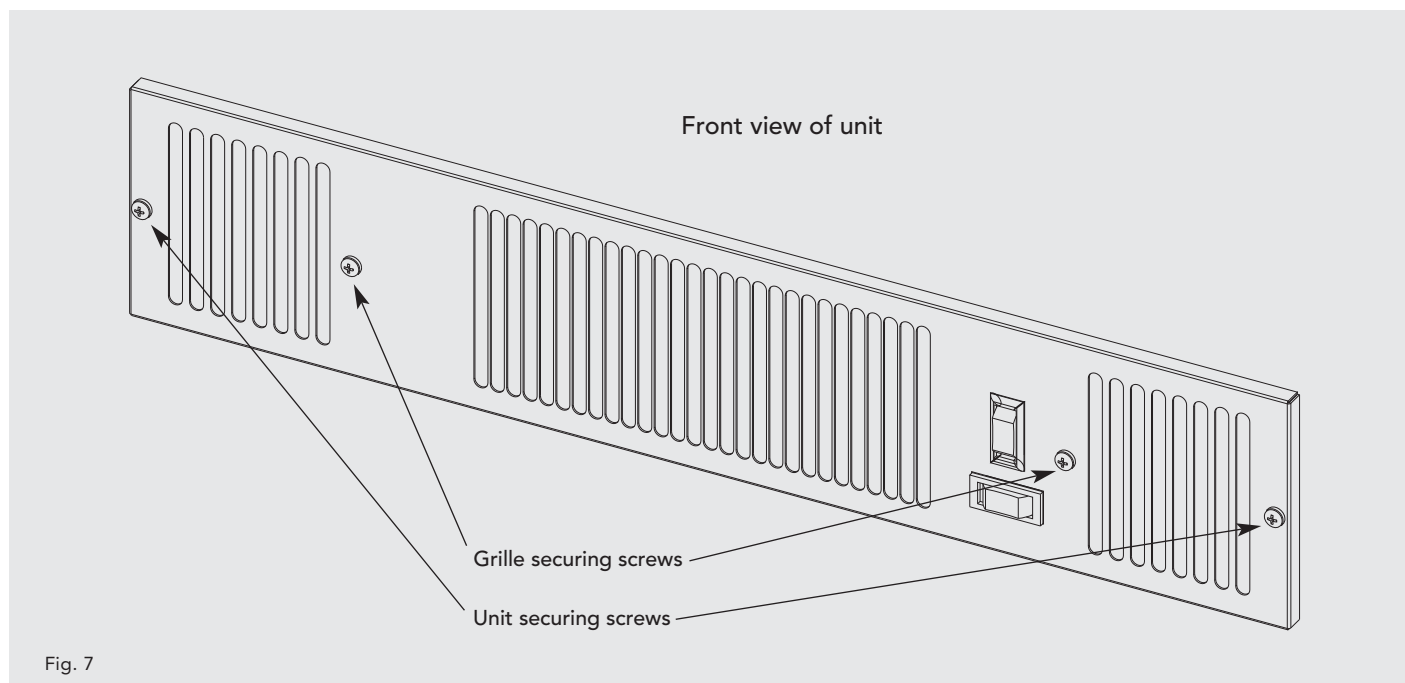

8.0 Fitting the KICKSPACE® (continued...)

- Complete the electrical installation, switch on and test the KICKSPACE®.

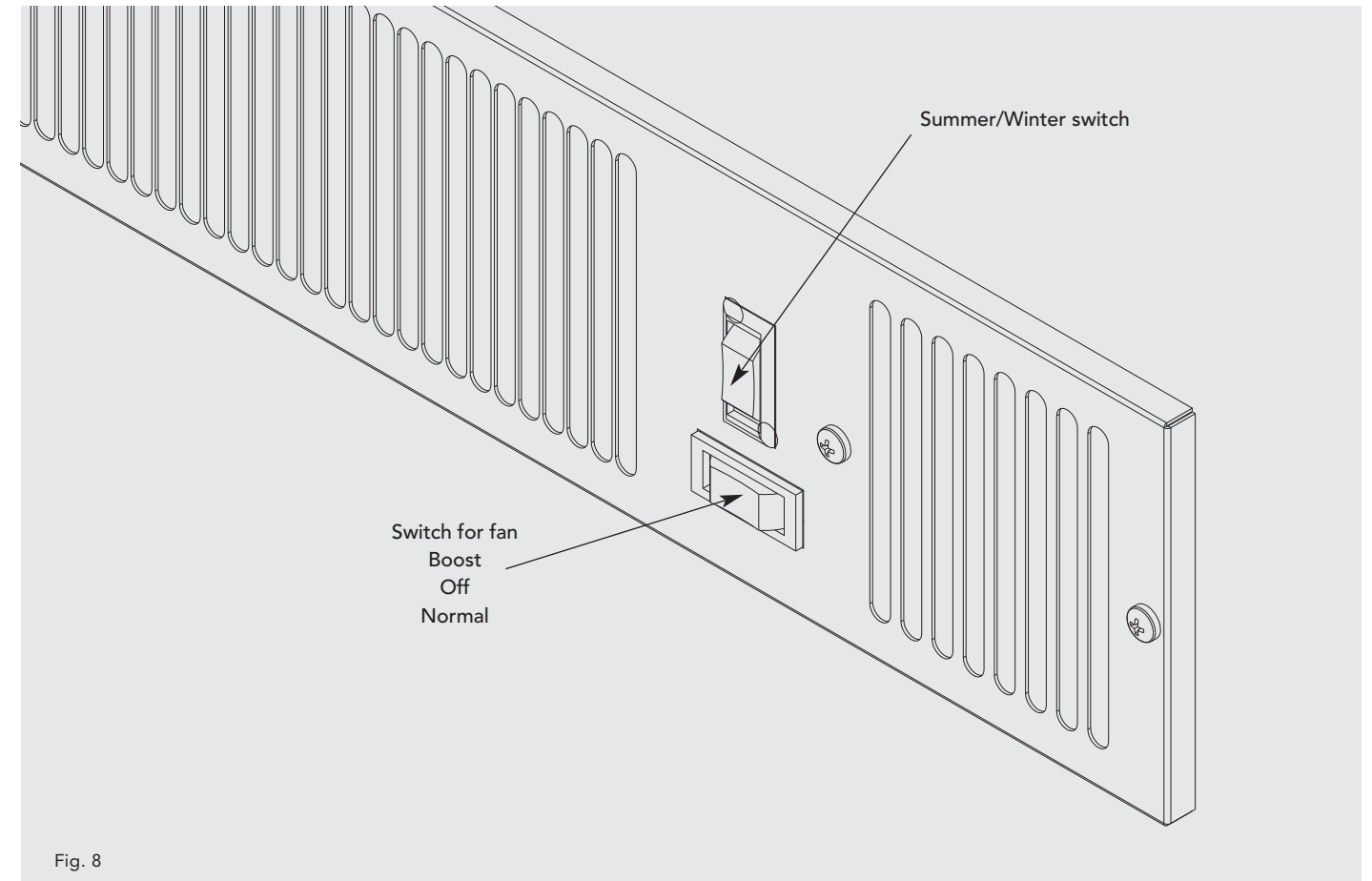

9.0 Technical Data

Dimensions

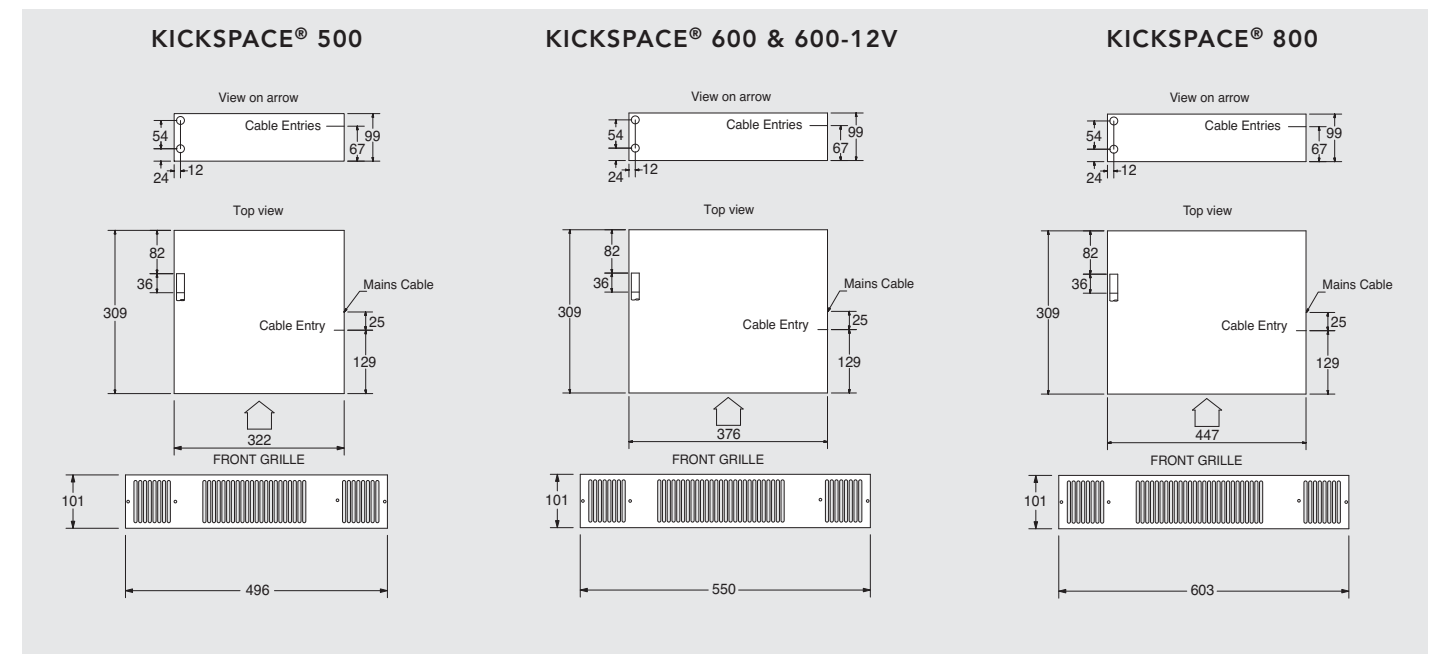

9.0 Technical Data

Heating Performance Data

Model	Fan Speed	Heat Output (watts)						Heat Output (Btu/h)					
		Temperature Difference (°C)						Temperature Difference (°F)					
		40°	45°	50°	55°	60°	65°	72°	81°	90°	99°	108°	117°
500	Normal	733	815	896	976	1056	1135	2501	2781	3058	3332	3603	3873
	Boost	923	1045	1166	1289	1412	1535	3152	3565	3981	4398	4817	5238
600	Normal	880	1053	1225	1393	1560	1730	3002	3594	4179	4754	5322	5904
	Boost	1275	1453	1630	1803	1975	2150	4350	4959	5561	6154	6738	7336
600-12V	Normal	880	1053	1225	1393	1560	1730	3002	3594	4179	4754	5322	5904
	Boost	1275	1453	1630	1803	1975	2150	4350	4959	5561	6154	6738	7336
800	Normal	1396	1552	1707	1860	2012	2162	4763	5295	5824	6346	6865	7377
	Boost	1738	1964	2192	2420	2649	2879	5930	6701	7479	8257	9038	9823

Heat outputs tested in accordance with BS 4856 Part 1.

Flow Rate: 340 ltr/h (75 gal/h).

Flow Rate Correction Factors:
 455 ltr/h (100 gal/h) multiply output by 1.03.
 227 ltr/h (50 gal/h) multiply output by 0.96.
 113 ltr/h (25 gal/h) multiply output by 0.85.

Approximate Hydraulic Resistance through Fan Convectors

Litres/h	mm wg				kPa			
	500	600	600-12V	800	500	600	600-12V	800
455	788	1046	1046	911	7.7	10.3	10.3	8.9
340	488	625	625	544	4.8	6.1	6.1	5.3
227	231	326	326	258	2.3	3.2	3.2	2.5
113	82	95	95	82	0.8	0.9	0.9	0.8

Noise Levels

Model	Sound Pressures at 2.5m (dBA)	
	Normal	Boost
500	25.7	38.1
600	26.4	37.2
600-12V	26.4	32.7
800	28.5	49.8

Noise levels tested in accordance with EN 23741.

Weight, Water Content and Motor Power

Model	Motor Power (W)	Water Content (l)	Unit Weight (kg)
500	25	0.15	5.5
600	40	0.30	5.9
600-12V	40	0.30	7.9*
800	40	0.18	5.5

*Includes transformer.

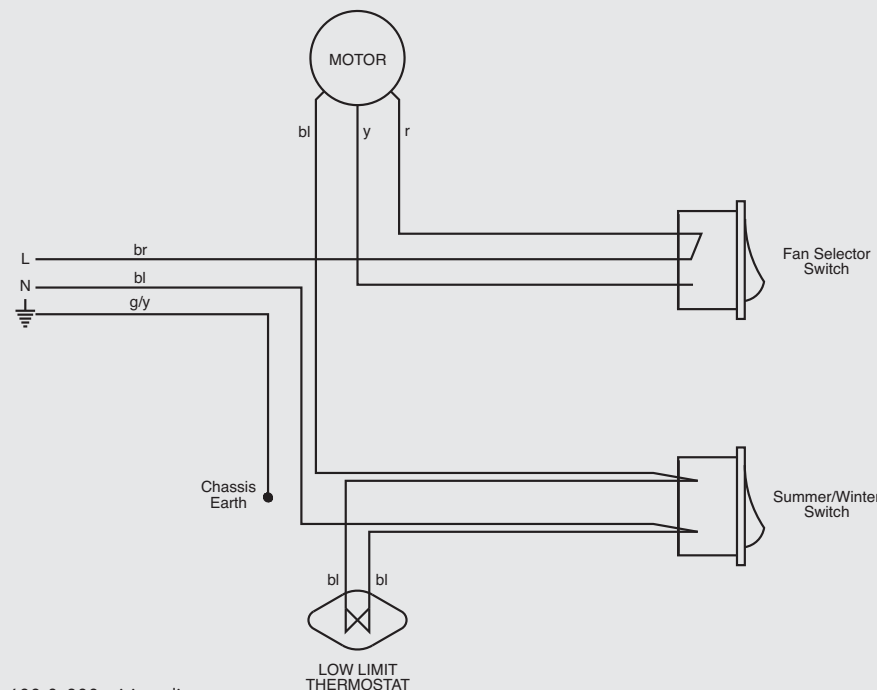

Fig. 10 KICKSPACE® 500, 600 & 800 wiring diagram

9.0 Technical Data (continued...)

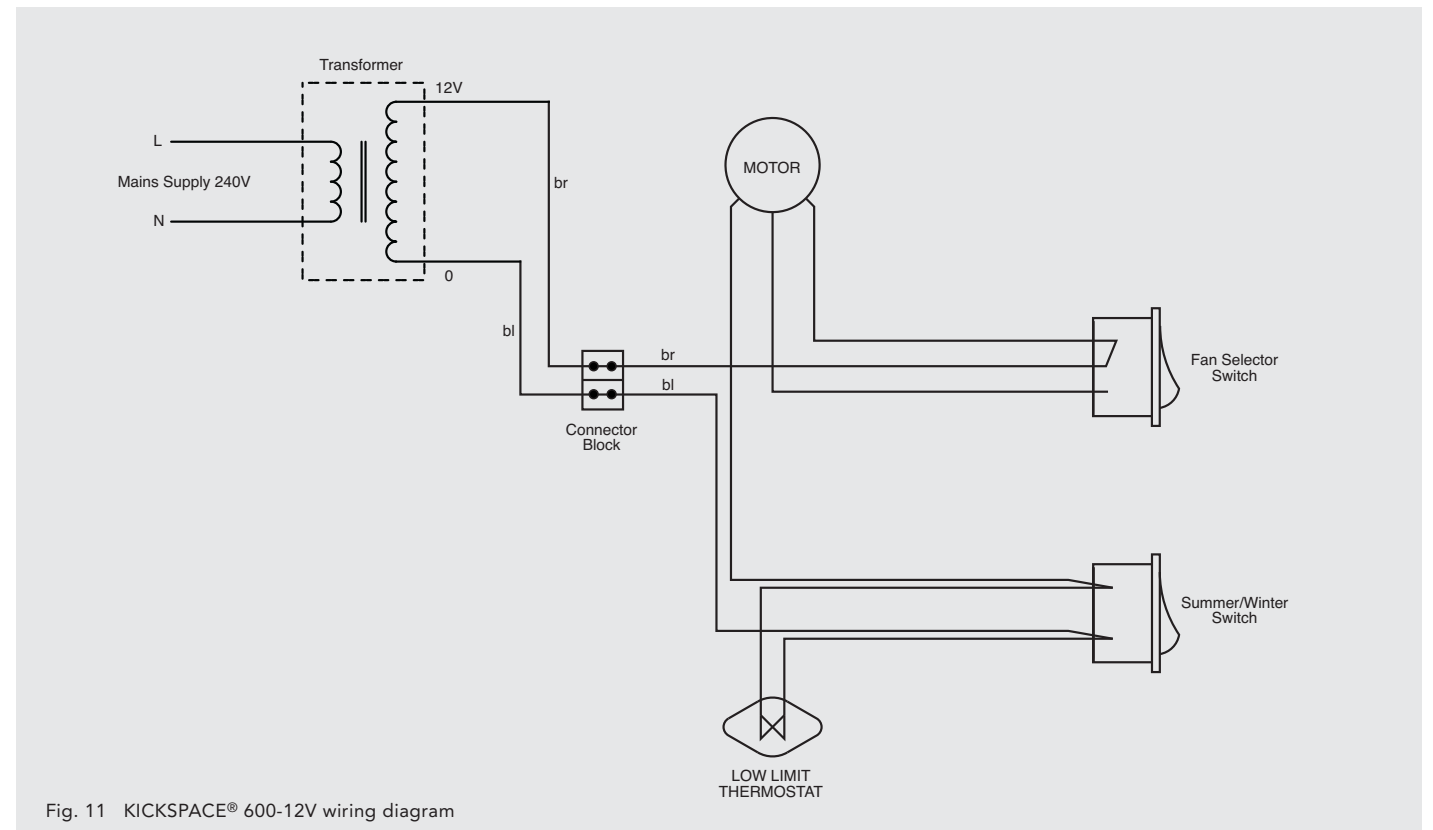

Fig. 11 KICKSPACE® 600-12V wiring diagram

10.0 Operating Instructions

This unit is controlled by the switches on the front of the unit, or by means of the wall mounted remote switching kit if fitted.

Ensure the electricity supply is switched on.

Heating Mode

- The fan will only operate when
- The central heating boiler is on
 - The pump is running
 - The system water temperature is greater than 43°C.

Ensure boiler is on, and set timer, boiler controls and room thermostats as necessary.

- Turn room thermostat to a high setting.
- Set summer - winter switch to ☀️
- Set fan speed control position I.
- The unit will now run on low fan speed. For satisfactory operation the mean water temperature should not be below 60°C.

Temperature Control

The room thermostat setting should be gradually adjusted to obtain the desired temperature.

The fan speed can be set to boost by switching the fan speed switch to II.

A low speed setting is recommended for normal operation with the higher speeds for boost heating when required.

Low Limit Operation

The low limit thermostat fitted to the KICKSPACE® will ensure that the fan stops after the heating system is switched off and the water flow stops. If left in an operating position the unit will automatically restart when the heating system is reheated.

Off Position

Set the fan speed selector switch to the off (O) position.

Summer Mode

If required, the KICKSPACE® can be used in Summer for air circulation without heat.

Set summer - winter switch to ⚙️
 Adjust fan speed to required setting.

If a remote control switch is fitted, the fan switch on the unit will be inoperative. Refer to the instructions supplied with the remote control switch for details.

11.0 Troubleshooting

Once installed this fan convector becomes an integral part of a complete heating system that includes boiler, pump, other emitters such as radiators and fan convectors, and a number of heating controls, dependent on system complexity. An apparent problem with this unit may be the result of system controls being incorrectly set and can be solved easily without calling out your

installer or MYSON Service. Before calling your installer or MYSON Service, please carry out the checks listed below.

Note: If you call out MYSON Service to a fault detailed below, or to repair a fault caused by incorrect use, a call out charge will be made.

Problem	Possible Causes	Remedy
Heating Mode - No Fan	Room thermostat not calling for heat	Turn up room thermostat
	Unit not switched on at fused spur	Switch on at spur
	Fuse blown at spur	Replace fuse
	Remote control switched off (if fitted)	Switch to heating mode
	Water temperature reaching unit	Check boiler -
	Below 43°C	Programmer ON Boiler ON and set to high Circulating pump running Note: Operation of fan convector can be checked by switching to summer setting
Heating Mode poor heating performance and/or unit cycles on low limit thermostat	Low water temperature to unit	Turn up boiler thermostat
	Poor water flow	Vent air from heating system

If the fan convector is still faulty after checking the above, call your installer or MYSON Service.

Common Installation Faults

For optimum performance, this unit must be correctly sized to match the heat loss requirements of the space it is required to

heat, and the heating system must be correctly designed to provide adequate flow of hot water to the unit (see Section 2). If the recommendations in Section 2 are not followed, problems may arise as detailed below.

Problem	Possible Causes
Poor heating performance	Unit incorrectly sized for heat loss of room
Poor heating performance (unit may cycle on low limit thermostat)	Boiler thermostat set too low
	Lack of flow to fan convector - Pump set on low setting
	Isolating valves not fully open
	System incorrectly balanced with unit starved of hot water flow
	Pipe sizing to unit too small

12.0 Maintenance

Before undertaking any maintenance activity isolate the electrical supply.

Maintenance should be restricted to occasional removal of dust and lint around the front grille.

This unit should be serviced periodically by a competent person.

This should involve internal cleaning of the heat exchanger using a soft brush or vacuum cleaner, taking care not to damage fan or heat exchanger.

Please see after sales service details on the back cover.

Spares List

Description	Part Number	Quantity
Motor / Fan Assembly KICKSPACE® 500	1200049	1
Motor / Fan Assembly KICKSPACE® 600	1200050	1
Motor / Fan Assembly KICKSPACE® 600-12V	1200050	1
Motor / Fan Assembly KICKSPACE® 800	1200050	1
Transformer	1200050	1
Switch, 3 way	1300025	1
Switch, 2 way	1300024	1
Low Limit Thermostat	1260007	1
Wiring Harness	1330041	1
15mm Valve & Flexible Hose	1252007	2
Brown Grille, KICKSPACE® 500	5000054	1
Brown Grille, KICKSPACE® 600	5000058	1
Brown Grille, KICKSPACE® 800	5000058	1
White Grille, KICKSPACE® 500	5000053	1
White Grille, KICKSPACE® 600	5000057	1
White Grille, KICKSPACE® 800	5000057	1
Black Grille, KICKSPACE® 500	5000061	1
Black Grille, KICKSPACE® 600	5000062	1
Black Grille, KICKSPACE® 800	5000062	1
Chrome Grille, KICKSPACE® 500	5000056	1
Chrome Grille, KICKSPACE® 600	5000060	1
Chrome Grille, KICKSPACE® 800	5000060	1
Brushed Stainless Steel, KICKSPACE® 500	5000126	1
Brushed Stainless Steel, KICKSPACE® 600	5000127	1
Brushed Stainless Steel, KICKSPACE® 800	5000127	1
Aluminium, KICKSPACE® 500	5000138	1
Aluminium, KICKSPACE® 600	5000139	1
Aluminium, KICKSPACE® 800	5000139	1