



NEW!



New iVECTOR S2 is the whisper-quiet fan convector from MYSON. With an attractive, compact design the iVECTOR S2 is capable of high heating performance whilst operating at low temperatures and with low water content. This provides efficient energy use without sacrificing outputs.

When combined with a reversible heat pump or a separate cooling source, the iVECTOR S2 can offer both heating and cooling functions, making it a perfect solution for both commercial and domestic use.

**Silence...listen**

At last here is a fan convector that offers innovative solutions for heating and cooling systems. Thanks to its ingenious and highly-accurate controls the iVECTOR S2 provides optimal comfort all year round. It is equipped with a highly-efficient DC motor, with performance and fan speed controlled using pulse width modulation (PWM) which significantly reduces noise and vibrations.

**Rapid heat-up and easy installation**

Due to its low water content the new iVECTOR S2 operates quickly and efficiently. Thanks to its simple design the iVECTOR S2 is very simple to install.

**Controls with a high IQ for smart homes**

Like no other fan convector, the iVECTOR S2 is ideally suited to modern building management systems and can be controlled centrally. Even individual users benefit from the simple-to-use controls. It's also possible in summer to operate in cooling mode and to cool rooms without using an air conditioning system.

**Slimline design**

Aesthetically pleasing, the iVECTOR S2's slimline design allows for discreet positioning without compromising performance. Whether surface mounted or recessed the iVECTOR S2 will blend into its environment seamlessly.



iVECTOR S2

iVECTOR S2

Not to be used in high humidity conditions.

iVECTOR S2

VS - Surface mounted models

Wall mounted



- Assembly is to be carried out using the supplied fixings

Ceiling mounted



- Assembly is to be carried out using the supplied fixings
- Horizontally mounted units using the cooling function require a condensate collector tray **C**
- Ceiling mounted units are available as either a Remote Control model† or 0-10V model

Wall mounted with optional pipe covers



- Assembly is to be carried out using the supplied fixings
- The optional decorative pipe covers (non weight-bearing), conceal the connections from the floor **A**

Floor mounted



- Floor mounting feet that anchor the iVECTOR to the ground and conceal connections from the floor **B**
- When installing in front of windows, a corresponding rear metal cover must be used **D**

†Remote control not included, see page 162.

Accessories** - VS

Ref.	Model	Order Code
A	Pipe covers/feet • Covers up supply and return pipes as they enter the unit. • They should be fitted on appliances anchored to the back wall. • These feet should not be used to anchor the iVECTOR S2 to the ground.	VS models VS-WALLPIPECOVER*
B	Floor mounting feet/pipe covers • For anchoring the unit to the ground. • Also covers any hydraulic pipes coming up through the floor.	VS models VS-FLOORBRACKETS*
C	Condensate collector tray Required for horizontally-mounted units in cooling applications. For 2P and 4P versions. Note: The condensate collector tray is included with VSI models.	VS-7 VS-9 VS-11 VS-13 VS-15 VS-7COLLECTOR* VS-9COLLECTOR* VS-11COLLECTOR* VS-13COLLECTOR* VS-15COLLECTOR*
D	Rear metal cover panel for 2P versions, white Cover panel for use when the unit is installed in front of windows. Rear metal cover panel for 4P versions, white Cover panel for use when the unit is installed in front of windows.	VS-7 2-Pipe VS-9 2-Pipe VS-11 2-Pipe VS-13 2-Pipe VS-15 2-Pipe VS-7 4-Pipe VS-9 4-Pipe VS-11 4-Pipe VS-13 4-Pipe VS-15 4-Pipe VS-7COVER2P* VS-9COVER2P* VS-11COVER2P* VS-13COVER2P* VS-15COVER2P* VS-7COVER4P* VS-9COVER4P* VS-11COVER4P* VS-13COVER4P* VS-15COVER4P*
Valve extension 81mm spacer for use with return valve when pipe connection is from the floor.		VS-STREXT*
90° angle EUROKONUS connector Elbow for use with flow valve when pipe connection is through the wall.		VS-ANGEXT*



*Non-stock - made to order only.
**Accessories sold separately.



VS SURFACE MOUNTED MODEL

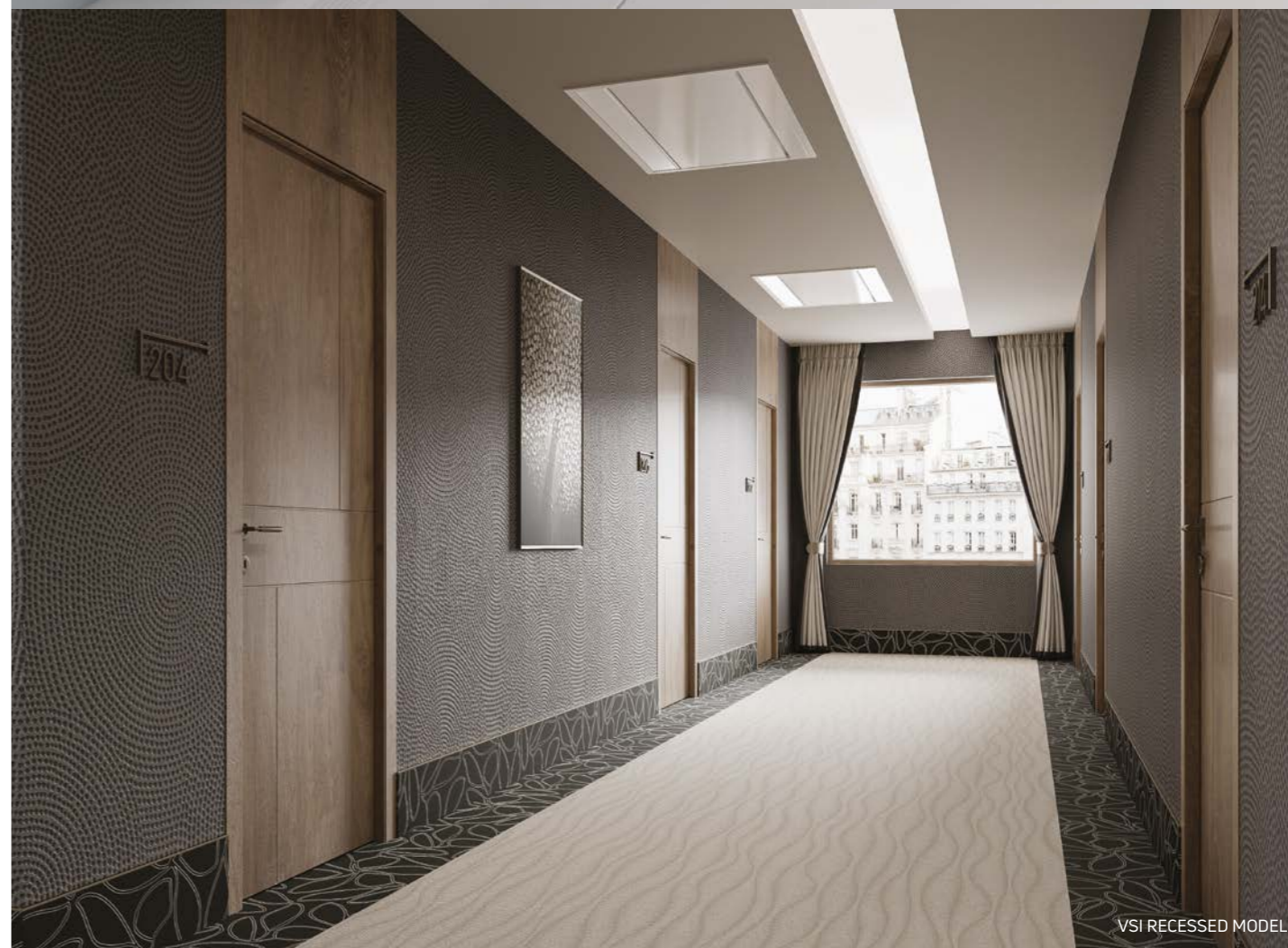

VSI RECESSED MODEL

iVECTOR S2

VSI - Recessed models

Supplied without controls, refer to page 162.



Wall recessed

When installing the iVECTOR S2 in a recessed wall, a metal casing **L** is required to house the iVECTOR and a vertical casing cover **M** for the front face.

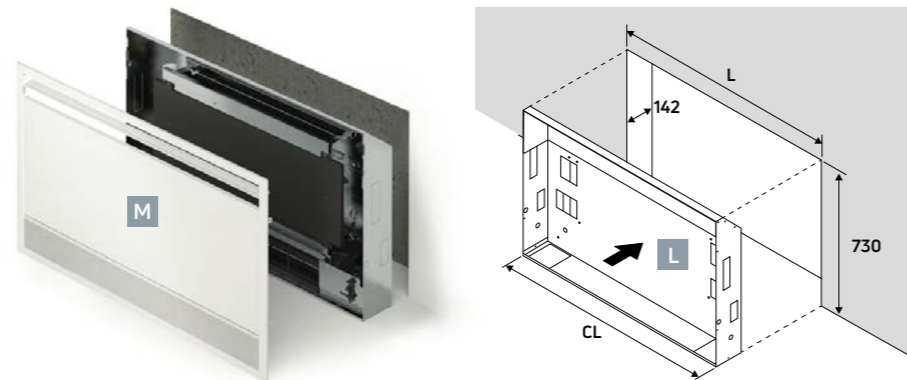

Model	Metal Casing L Dimensions (mm)			Wall Cut-Out Dimensions (mm)		
	Height	Casing Length (CL)	Depth	Height	Length (L)	Depth
VSI-7	725	715	142	730	740	142
VSI-9		915			940	
VSI-11		1115			1140	
VSI-13		1315			1340	
VSI-15		1515			1540	

Ceiling recessed

<p>Installing from a suspended ceiling with both air intake and outlet on bottom</p>	<p>Installing from a suspended ceiling with suction from bottom and horizontal air outlet</p>	<p>Installing in a recessed ceiling with metal casing</p>
<p>Accessories Required</p>	<p>Accessories Required</p>	<p>Accessories Required</p>

NB: The air inlet grilles and air outlet grilles can only be attached to the corresponding air ducts (**E** , **F** and **G**) and not directly to the device!

Accessories** - VSI

Ref.		Model	Order Code
E	Air intake adapter Used with recessed versions when the unit will sit within a false ceiling cavity and the air intake adapter will be exposed.	VSI-7 VSI-9 VSI-11 VSI-13 VSI-15	VSI-7AIRADAPT* VSI-9AIRADAPT* VSI-11AIRADAPT* VSI-13AIRADAPT* VSI-15AIRADAPT*
F	Variable length air flow duct Used with recessed version where outlet needs to be sited away from unit. Min length 302mm, max length 590mm.	VSI-7 VSI-9 VSI-11 VSI-13 VSI-15	VSI-7AIRDUCT* VSI-9AIRDUCT* VSI-11AIRDUCT* VSI-13AIRDUCT* VSI-15AIRDUCT*
G	90° air outlet duct Used with recessed versions where unit will sit in false ceiling cavity and outlet grille will be exposed.	VSI-7 VSI-9 VSI-11 VSI-13 VSI-15	VSI-7DUCT90* VSI-9DUCT90* VSI-11DUCT90* VSI-13DUCT90* VSI-15DUCT90*
H	Air outlet grille straight Used with recessed versions. Grille vanes are straight.	VSI-7 VSI-9 VSI-11 VSI-13 VSI-15	VSI-7OUTSTR* VSI-9OUTSTR* VSI-11OUTSTR* VSI-13OUTSTR* VSI-15OUTSTR*
I	Air inlet grille straight Used with recessed versions. Grille vanes are straight.	VSI-7 VSI-9 VSI-11 VSI-13 VSI-15	VSI-7INSTR* VSI-9INSTR* VSI-11INSTR* VSI-13INSTR* VSI-15INSTR*
J	Air outlet grille curved Used with recessed versions. Grille vanes are curved to direct airflow away from room occupants.	VSI-7 VSI-9 VSI-11 VSI-13 VSI-15	VSI-7OUTCUR* VSI-9OUTCUR* VSI-11OUTCUR* VSI-13OUTCUR* VSI-15OUTCUR*
K	Air inlet grille curved Used with recessed versions. Grille vanes are curved to direct airflow away from room occupants.	VSI-7 VSI-9 VSI-11 VSI-13 VSI-15	VSI-7INCUR* VSI-9INCUR* VSI-11INCUR* VSI-13INCUR* VSI-15INCUR*
L	Metal casing for recessed fan convectors Required for fan convectors with front cover. iVECTOR S2 mounts directly into metal casing. Requires front cover, see page 160.	VSI-7 2-Pipe VSI-9 2-Pipe VSI-11 2-Pipe VSI-13 2-Pipe VSI-15 2-Pipe VSI-7 4-Pipe VSI-9 4-Pipe VSI-11 4-Pipe VSI-13 4-Pipe VSI-15 4-Pipe	VSI-7CASING2P* VSI-9CASING2P* VSI-11CASING2P* VSI-13CASING2P* VSI-15CASING2P* VSI-7CASING4P* VSI-9CASING4P* VSI-11CASING4P* VSI-13CASING4P* VSI-15CASING4P*
M	Vertical casing front cover Vertical casing cover with air intake grille. For use with standard metal casing L .	VSI-7 2-Pipe VSI-9 2-Pipe VSI-11 2-Pipe VSI-13 2-Pipe VSI-15 2-Pipe VSI-7 4-Pipe VSI-9 4-Pipe VSI-11 4-Pipe VSI-13 4-Pipe VSI-15 4-Pipe	VSI-7WALLCVR2P* VSI-9WALLCVR2P* VSI-11WALLCVR2P* VSI-13WALLCVR2P* VSI-15WALLCVR2P* VSI-7WALLCVR4P* VSI-9WALLCVR4P* VSI-11WALLCVR4P* VSI-13WALLCVR4P* VSI-15WALLCVR4P*
N	Ceiling casing front cover Ceiling casing cover with air intake grille. For use with standard metal casing L .	VSI-7 2-Pipe VSI-9 2-Pipe VSI-11 2-Pipe VSI-13 2-Pipe VSI-15 2-Pipe VSI-7 4-Pipe VSI-9 4-Pipe VSI-11 4-Pipe VSI-13 4-Pipe VSI-15 4-Pipe	VSI-7CEILCVR2P* VSI-9CEILCVR2P* VSI-11CEILCVR2P* VSI-13CEILCVR2P* VSI-15CEILCVR2P* VSI-7CEILCVR4P* VSI-9CEILCVR4P* VSI-11CEILCVR4P* VSI-13CEILCVR4P* VSI-15CEILCVR4P*
	Valve extension 81mm spacer for use with return valve when pipe connection is from the floor.		VS-STREXT*
	90° angle EUROKONUS connector Elbow for use with flow valve when pipe connection is through the wall.		VS-ANGEXT*

*Non-stock - made to order only.
**Accessories sold separately.

iVECTOR S2

Control options

Integrated control

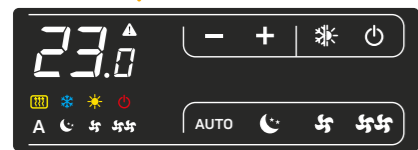

The Integrated Control comes with different control functions:

- **AUTO** - Determines the automatic adjustment of the fan speed as a function of the difference between room temperature and set temperature
- **NIGHT** - Fan speed is limited to a set level and the set temperature is adjusted automatically; reduced in heating mode and increased in cooling mode
- **SILENT** - Fan speed is limited to achieve lower sound levels
- **MAXIMUM FAN SPEED** - Allows rapid achievement of the desired temperature conditions by activating the maximum possible power level

Note: It is not possible to control other units with the Integrated Control.

Remote control†



†Not included with Remote Control iVECTOR S2 - order separately.

With this control option, up to 30 fan convectors can be managed using a single Remote Control.

The connection to the iVECTOR S2 is made using an RS485 Data Cable (not included).

The Remote Control **RC** is available in Black and White.

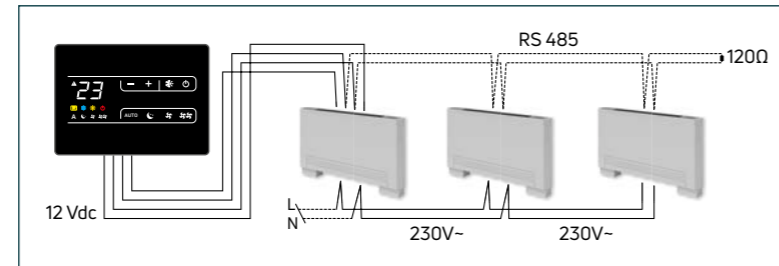

Ref.	Model	Order Code
RC	Remote control Wall-mounted remote control.	S2WALLREMBL* S2WALLREMWH*

*Non-stock - made to order only.

0-10V DC control board





iVECTOR S2 is available with a 0-10V DC control board option which allows the unit to be controlled centrally from a BMS system using a 0-10V analogue input. Suitable external thermostat or building's own BMS system required.





0-10V for Building Management System



iVECTOR S2

General specification

-  **CERTIFICATION**
Produced under a quality management system - ISO 9001:2015, environmental management system - ISO 14001:2015 and Occupational health and safety management system - ISO 45001:2018. Carries the CE mark and conforms to the Low Voltage Directive 2014/35/EU and the EMC Directive 2014/30/EU. Sound levels are tested to EN 23741.
-  **GUARANTEE**
2 year guarantee from date of purchase against manufacturing defects.
-  **COLOUR**
Finished in white (RAL 9003) powder coating.
-  **SYSTEM**
Closed circulation, 2 pipe pump assisted central heating systems.
-  **CONNECTIONS**
2 x 3/4" internal thread connections on 2 pipe versions.
4 x 3/4" internal thread connections on special 4 pipe versions.

-  **AIR VENTS**
Integrated.
-  **OPERATING PRESSURES**
Tested to a pressure of 20 bar.
Working pressure of up to 10 bar.
-  **OPERATING TEMPERATURE**
Maximum 85°C.
-  **ELECTRICAL SUPPLY**
220-240V - 50Hz fused at 3A.
-  **DELIVERY**
2 - 5 working days.
Non-stocked items: 8 - 12 weeks.

For more general information, please see page 264.

Heating and cooling options

2-Pipe model

With a 2-pipe system, fan convectors can normally only be used for either heating or cooling, through either connecting to a heat source or connecting to a chiller. However, if a reverse cycle heat pump is installed in the system, then it is possible for all iVECTOR S2 fan convectors on the system to operate in both heating and cooling modes, depending on which cycle the heat pump is in. A key point to note is that both the heated and chilled water flow through the same 2 pipes, therefore, the entire system must be in either heating or cooling mode.

4-Pipe model

The 4-pipe iVECTOR S2 is capable of providing both heating and cooling to different parts of the same building at the same time. It has two pipes connecting to a heat source and two pipes connecting to a chiller. This feature enables an enhanced indoor comfort solution within the same building.

iVECTOR S2

Technical information

2-Pipe models

Parameter	Metric	Units	Model				
			VS-7 VSI-7	VS-9 VSI-9	VS-11 VSI-11	VS-13 VSI-13	VS-15 VSI-15
Heating/ Cooling	Total cooling (7/12/27°C)	kW med (min - max)*1	0.73 (0.43 - 0.91)	1.36 (0.75 - 2.12)	2.08 (1.15 - 2.81)	2.39 (1.32 - 3.30)	2.57 (1.41 - 3.71)
	Sensible cooling	kW med (min - max)*1	0.51 (0.29 - 0.71)	1.04 (0.59 - 1.54)	1.51 (0.83 - 2.11)	1.84 (1.02 - 2.65)	1.98 (1.05 - 2.90)
	Flow rate	L/h med (min - max)*1	125.3 (73.6 - 156.1)	233.3 (128.7 - 363.8)	356.9 (197.3 - 482.1)	410.1 (226.5 - 556.2)	441.0 (233.3 - 636.6)
	Pressure drop	kPa med (min - max)*1	10.2 (5.7 - 12.1)	4.3 (1.9 - 8.2)	9.9 (2.7 - 17.1)	8.8 (2.5 - 18.0)	11.1 (3.4 - 21.2)
	Heating (75/65/20°C)	kW med (min - max)*1	1.51 (0.81 - 2.21)	3.28 (1.85 - 4.71)	4.79 (2.68 - 6.62)	5.81 (3.29 - 8.42)	6.33 (3.34 - 9.54)
	Flow rate	L/h med (min - max)*1	132.7 (71.5 - 194.7)	289.0 (162.5 - 414.3)	421.5 (236.1 - 582.4)	510.9 (289.7 - 740.9)	556.7 (293.9 - 839.8)
Pressure drop	kPa med (min - max)*1	2.8 (0.9 - 6.5)	3.4 (1.7 - 5.0)	9.3 (3.0 - 16.1)	10.2 (3.4 - 18.2)	8.0 (3.4 - 24.0)	
Hydraulic	Heat exchanger water volume	l	0.47	0.80	1.13	1.46	1.80
	Max. operating pressure	bar	10	10	10	10	10
	Operating temperatures	°C (min - max)	4 - 80	4 - 80	4 - 80	4 - 80	4 - 80
	Pipe S/R connections*2	Inch	Eurocone 3/4"	Eurocone 3/4"	Eurocone 3/4"	Eurocone 3/4"	Eurocone 3/4"
	Condensate drain size	mm	14	14	14	14	14
Air Flow	Airflow*3	m³/h med (min - max)	91 (49 - 146)	210 (124 - 294)	318 (194 - 438)	410 (302 - 567)	479 (364 - 663)
Electrical	Power supply	V/ph/Hz	230/1/50	230/1/50	230/1/50	230/1/50	230/1/50
	Max. power	W	11	19	20	29	33
	Max. power @ min. speed	W	4	4	5	5	5
Acoustics	Sound power	dB(A) med (min - max)*1	44 (33 - 51)	45 (35 - 53)	46 (36 - 54)	47 (36 - 55)	48 (37 - 57)
	Sound pressure*4	dB(A) med (min - max)*1	33 (24 - 41)	34 (25 - 42)	34 (26 - 44)	35 (26 - 46)	38 (28 - 47)

4-Pipe models

Parameter	Metric	Units	Model				
			VS-7 VSI-7	VS-9 VSI-9	VS-11 VSI-11	VS-13 VSI-13	VS-15 VSI-15
Heating/ Cooling	Total cooling (7/12/27°C)	kW med (min - max)*1	0.61 (0.31 - 0.72)	1.13 (0.62 - 1.48)	1.52 (0.79 - 2.06)	1.79 (0.98 - 2.50)	2.18 (1.21 - 3.00)
	Sensible cooling	kW med (min - max)*1	0.45 (0.23 - 0.56)	0.84 (0.46 - 1.15)	1.11 (0.61 - 1.54)	1.41 (0.81 - 1.97)	1.68 (0.93 - 2.31)
	Flow rate	L/h med (min - max)*1	105.4 (52.5 - 124.2)	193.0 (106.3 - 253.5)	260.2 (134.7 - 353.6)	306.4 (168.9 - 428.5)	374.3 (207.8 - 514.2)
	Pressure drop	kPa med (min - max)*1	7.4 (3.9 - 8.4)	5.3 (3.5 - 6.6)	9.7 (4.9 - 13.7)	7.3 (4.0 - 10.8)	6.5 (3.7 - 8.5)
	Heating (75/65/20°C)	kW med (min - max)*1	0.62 (0.38 - 0.71)	1.24 (0.81 - 1.44)	1.74 (1.28 - 2.04)	2.54 (1.76 - 2.90)	2.73 (1.87 - 3.28)
	Flow rate	L/h med (min - max)*1	54.2 (33.6 - 62.6)	108.8 (71.0 - 126.8)	153.5 (112.9 - 179.6)	223.5 (154.7 - 255.3)	240.1 (164.6 - 288.7)
Pressure drop	kPa med (min - max)*1	3.2 (2.7 - 3.4)	3.1 (2.8 - 5.7)	6.8 (6.2 - 9.0)	4.9 (3.8 - 6.1)	4.2 (3.2 - 9.5)	
Hydraulic	Water content cooling	l	0.47	0.80	1.13	1.46	1.80
	Water content heating	l	0.16	0.27	0.38	0.49	0.60
	Max. operating pressure	bar	10	10	10	10	10
	Operating temperatures	°C (min - max)	4 - 80	4 - 80	4 - 80	4 - 80	4 - 80
	Pipe S/R connections*2	Inch	Eurocone 3/4"	Eurocone 3/4"	Eurocone 3/4"	Eurocone 3/4"	Eurocone 3/4"
Condensate drain size	mm	14	14	14	14	14	
Air Flow	Airflow*3	m³/h med (min - max)	91 (46 - 132)	207 (124 - 260)	291 (194 - 370)	367 (247 - 476)	416 (262 - 542)
Electrical	Power supply	V/ph/Hz	230/1/50	230/1/50	230/1/50	230/1/50	230/1/50
	Max. power	W	11	19	20	29	33
	Max. power @ min. speed	W	4	4	4	4	5
Acoustics	Sound power	dB(A) med (min - max)*1	44 (33 - 51)	45 (35 - 53)	46 (36 - 54)	47 (36 - 55)	48 (37 - 57)
	Sound pressure*4	dB(A) med (min - max)*1	33 (24 - 41)	34 (25 - 42)	34 (25 - 44)	35 (26 - 46)	37 (27 - 47)

*1: In Auto mode, values will vary between min-max.

*2: Supply/return piping is on the left side of the unit. Right side connections also available (MTO only).

*3: Airflow measured with clean filters

*4: Sound pressure measured in semianechoic chamber in compliance with ISO 7779 (distance 3m) - onsite conditions will result in different values

iVECTOR S2

Technical information (cont...)

FAN CONNECTORS

FAN CONNECTORS

Product dimensions & weights VS - 2-Pipe models

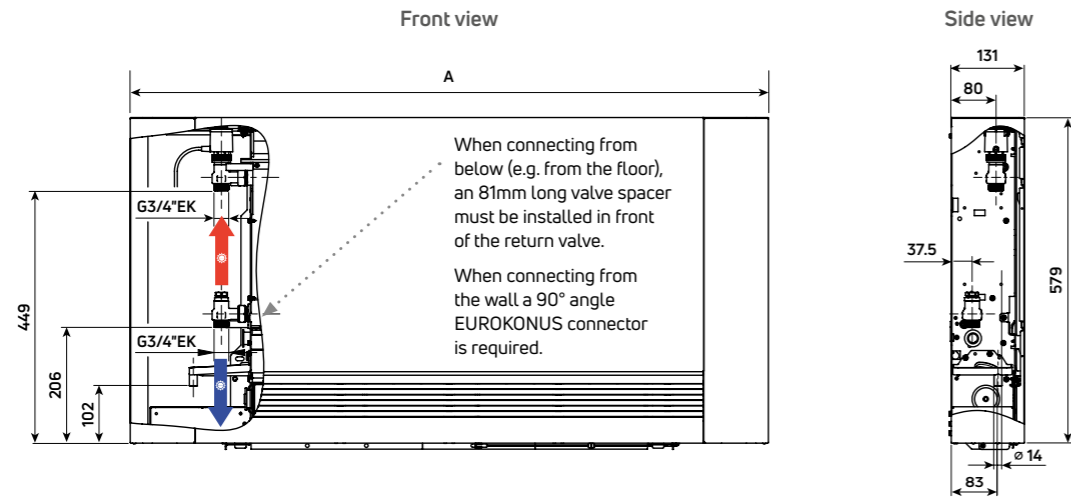

Note: Optional feet are 82mm

	Unit	VS-7	VS-9	VS-11	VS-13	VS-15
Dimension A	mm	735	935	1135	1335	1535
Weight (net)	kg	17	20	23	26	29

Product dimensions & weights VSI - 2-Pipe models

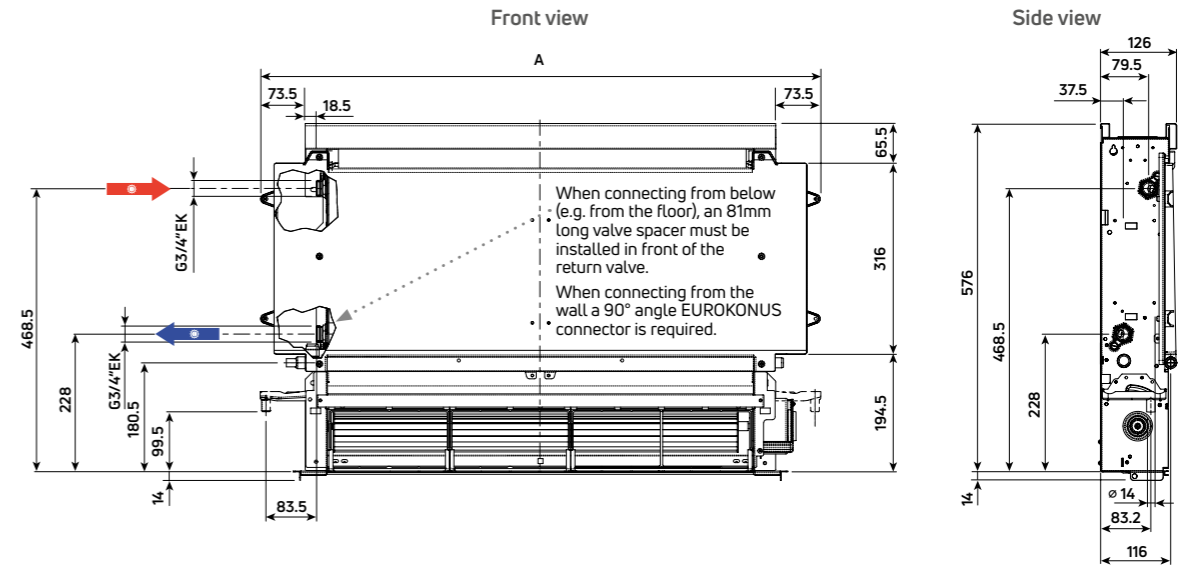

	Unit	VSI-7	VSI-9	VSI-11	VSI-13	VSI-15
Dimension A	mm	525	725	925	1125	1325
Weight (net)	kg	9	12	15	18	21

Product dimensions & weights VS - 4-Pipe models

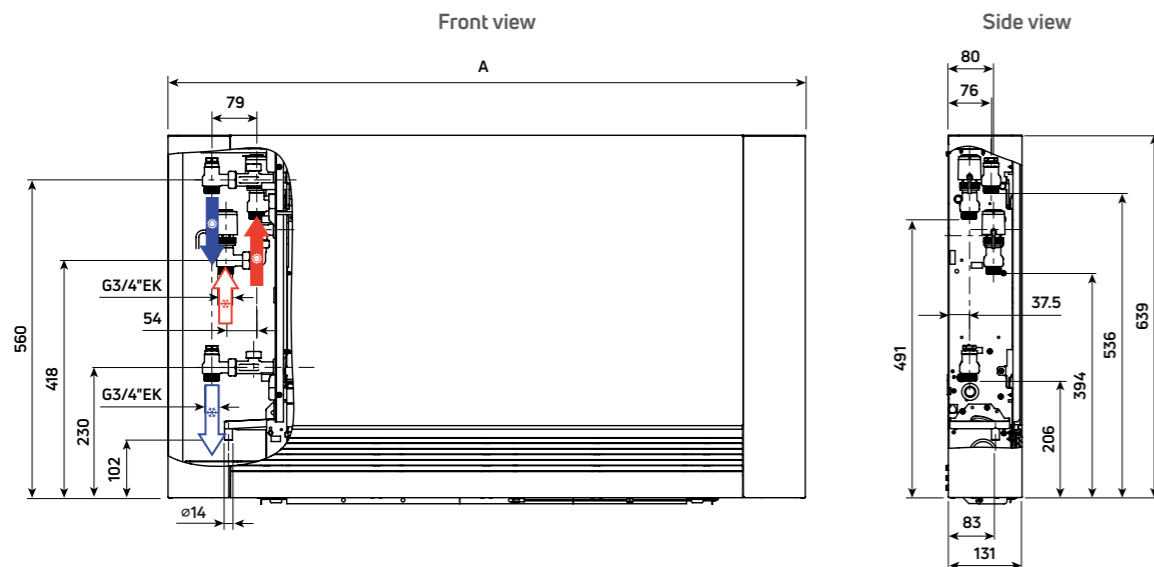

Note: Optional feet are 82mm

	Unit	VS-7	VS-9	VS-11	VS-13	VS-15
Dimension A	mm	735	935	1135	1335	1535
Weight (net)	kg	18	21	25	28	32

Product dimensions & weights VSI - 4-Pipe models

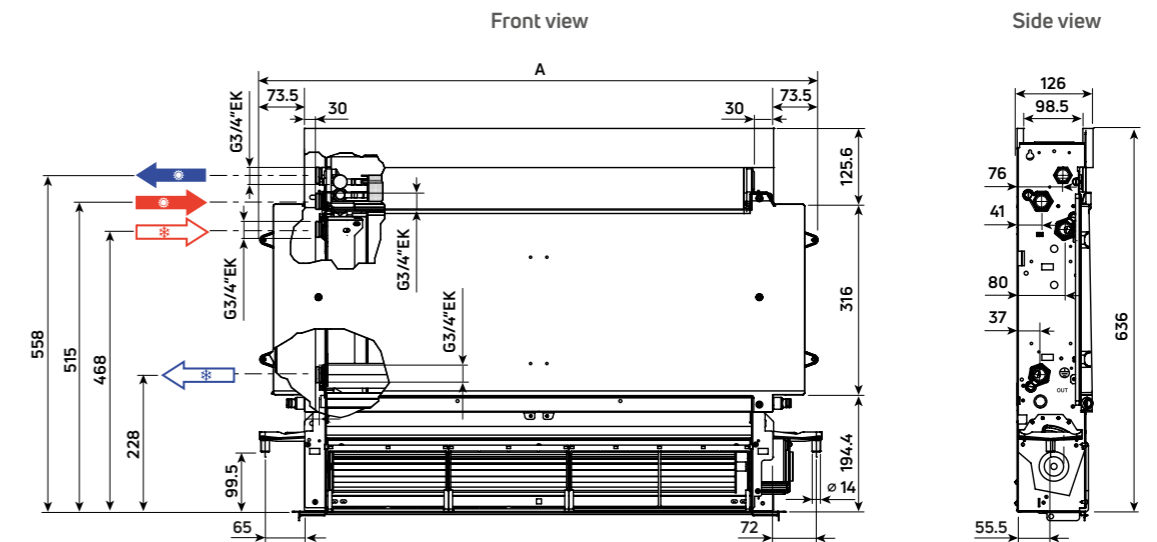

	Unit	VSI-7	VSI-9	VSI-11	VSI-13	VSI-15
Dimension A	mm	525	725	925	1125	1325
Weight (net)	kg	10	13	17	20	24

Note: 2 and 4-pipe recessed unit shown without factory-fitted valves (included).

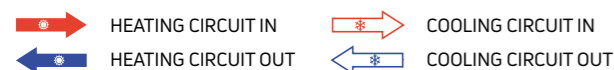

iVECTOR S2

Heat outputs

VS - 2-Pipe models

Unit/Model	Overall Height	Overall Depth	Overall Length	Fan Speed	Heat Output (W)		Cooling Output (W)		Order Code
					ΔT 22.5°C	ΔT 50°C	7/12/27°C		
					45/40/20°C	75/65/20°C	Total	Sensible	
VS-7	579	131	735	Min.	370	810	430	290	INTEGRATED CONTROL VS-7L2IC REMOTE CONTROL VS-7L2RC* 0-10V VS-7L20V*
				Med.	690	1510	730	510	
				Max.	1020	2210	910	710	
VS-9	579	131	935	Min.	820	1850	750	590	INTEGRATED CONTROL VS-9L2IC REMOTE CONTROL VS-9L2RC* 0-10V VS-9L20V*
				Med.	1530	3280	1360	1040	
				Max.	2210	4710	2120	1540	
VS-11	579	131	1135	Min.	1200	2680	1150	830	INTEGRATED CONTROL VS-11L2IC REMOTE CONTROL VS-11L2RC* 0-10V VS-11L20V*
				Med.	2160	4790	2080	1510	
				Max.	3020	6620	2810	2110	
VS-13	579	131	1335	Min.	1470	3290	1320	1020	INTEGRATED CONTROL VS-13L2IC REMOTE CONTROL VS-13L2RC* 0-10V VS-13L20V*
				Med.	2590	5810	2390	1840	
				Max.	3810	8420	3300	2650	
VS-15	579	131	1535	Min.	1940	3340	1410	1070	INTEGRATED CONTROL VS-15L2IC REMOTE CONTROL VS-15L2RC* 0-10V VS-15L20V*
				Med.	2820	6330	2570	1980	
				Max.	4320	9540	3710	2900	

- The standard VS 2-pipe 'INTEGRATED CONTROL' variant has a factory-fitted control unit on the iVECTOR.
- The VS 2-pipe 'REMOTE CONTROL' variant is supplied without a control unit, which can be ordered separately as an accessory, see RC page 162.
- For use with BMS systems or a compatible thermostat, the '0-10V' variant should be used.
- All VS 2-pipe variants are equipped with an automatic, electric 2-way valve set with ¾" Eurocone connections in 2-pipe design.

VS - 4-Pipe models

Unit/Model	Overall Height	Overall Depth	Overall Length	Fan Speed	Heat Output (W)		Cooling Output (W)		Order Code
					ΔT 22.5°C	ΔT 50°C	7/12/27°C		
					45/40/20°C	75/65/20°C	Total	Sensible	
VS-7	639	131	735	Min.	170	380	310	230	INTEGRATED CONTROL VS-7L4IC* REMOTE CONTROL VS-7L4RC* 0-10V VS-7L40V*
				Med.	240	620	610	450	
				Max.	290	710	720	560	
VS-9	639	131	935	Min.	350	810	630	460	INTEGRATED CONTROL VS-9L4IC* REMOTE CONTROL VS-9L4RC* 0-10V VS-9L40V*
				Med.	520	1240	1130	840	
				Max.	610	1440	1480	1150	
VS-11	639	131	1135	Min.	520	1280	790	610	INTEGRATED CONTROL VS-11L4IC* REMOTE CONTROL VS-11L4RC* 0-10V VS-11L40V*
				Med.	700	1740	1520	1110	
				Max.	820	2040	2060	1540	
VS-13	639	131	1335	Min.	590	1760	980	810	INTEGRATED CONTROL VS-13L4IC* REMOTE CONTROL VS-13L4RC* 0-10V VS-13L40V*
				Med.	860	2540	1790	1410	
				Max.	1000	2900	2500	1970	
VS-15	639	131	1535	Min.	630	1870	1210	930	INTEGRATED CONTROL VS-15L4IC* REMOTE CONTROL VS-15L4RC* 0-10V VS-15L40V*
				Med.	1150	2730	2180	1680	
				Max.	1390	3280	3000	2310	

- The standard VS 4-pipe 'INTEGRATED CONTROL' variant has a factory-fitted control unit on the iVECTOR.
- The VS 4-pipe 'REMOTE CONTROL' variant is supplied without a control unit, which can be ordered separately as an accessory, see RC page 162.
- For use with BMS systems or a compatible thermostat, the '0-10V' variant should be used.
- All VS 4-pipe variants are equipped with an automatic, electric 2-way valve set with ¾" Eurocone connections in 4-pipe design.

VSI - 2-Pipe models

Unit/Model	Overall Height	Overall Depth	Overall Length	Fan Speed	Heat Output (W)		Cooling Output (W)		Order Code
					ΔT 22.5°C	ΔT 50°C	7/12/27°C		
					45/40/20°C	75/65/20°C	Total	Sensible	
VSI-7	576	126	525	Min.	370	810	430	290	REMOTE CONTROL VS-7L2RC* 0-10V VS-7L20V*
				Med.	690	1510	730	510	
				Max.	1020	2210	910	710	
VSI-9	576	126	725	Min.	820	1850	750	590	REMOTE CONTROL VS-9L2RC* 0-10V VS-9L20V*
				Med.	1530	3280	1360	1040	
				Max.	2210	4710	2120	1540	
VSI-11	576	126	925	Min.	1200	2680	1150	830	REMOTE CONTROL VS-11L2RC* 0-10V VS-11L20V*
				Med.	2160	4790	2080	1510	
				Max.	3020	6620	2810	2110	
VSI-13	576	126	1125	Min.	1470	3290	1320	1020	REMOTE CONTROL VS-13L2RC* 0-10V VS-13L20V*
				Med.	2590	5810	2390	1840	
				Max.	3810	8420	3300	2650	
VSI-15	576	126	1325	Min.	1940	3340	1410	1070	REMOTE CONTROL VS-15L2RC* 0-10V VS-15L20V*
				Med.	2820	6330	2570	1980	
				Max.	4320	9540	3710	2900	

- All VSI 2-pipe variants include a factory-installed PCB control board, an automatic, electric 2-way valve set with ¾" Eurocone connections in 2-pipe design.
- The Remote Control variant is available to connect to the wall-mounted Remote Control which can be ordered separately as an accessory, see RC page 162.
- For use with BMS systems or a compatible thermostat, select the 0-10V variant.

VSI - 4-Pipe models

Unit/Model	Overall Height	Overall Depth	Overall Length	Fan Speed	Heat Output (W)		Cooling Output (W)		Order Code
					ΔT 22.5°C	ΔT 50°C	7/12/27°C		
					45/40/20°C	75/65/20°C	Total	Sensible	
VSI-7	636	126	525	Min.	170	380	310	230	REMOTE CONTROL VS-7L4RC* 0-10V VS-7L40V*
				Med.	240	620	610	450	
				Max.	290	710	720	560	
VSI-9	636	126	725	Min.	350	810	630	460	REMOTE CONTROL VS-9L4RC* 0-10V VS-9L40V*
				Med.	520	1240	1130	840	
				Max.	610	1440	1480	1150	
VSI-11	636	126	925	Min.	520	1280	790	610	REMOTE CONTROL VS-11L4RC* 0-10V VS-11L40V*
				Med.	700	1740	1520	1110	
				Max.	820	2040	2060	1540	
VSI-13	636	126	1125	Min.	590	1760	980	810	REMOTE CONTROL VS-13L4RC* 0-10V VS-13L40V*
				Med.	860	2540	1790	1410	
				Max.	1000	2900	2500	1970	
VSI-15	636	126	1325	Min.	630	1870	1210	930	REMOTE CONTROL VS-15L4RC* 0-10V VS-15L40V*
				Med.	1150	2730	2180	1680	
				Max.	1390	3280	3000	2310	

- All VSI 4-pipe variants include a factory-installed PCB control board, an automatic, electric 4-way valve set with ¾" Eurocone connections in 4-pipe design.
- The Remote Control variant is available to connect to the wall-mounted Remote Control which can be ordered separately as an accessory, see RC page 162.
- For use with BMS systems or a compatible thermostat, select the 0-10V variant.

*Non-stock - made to order only.